

3			2		1	
REV	ZONE	ECO	DESCRIPTION		DATE	DRAWN
A			Initial release		4/22/2010	EJ

D

C

B

A

D

C

B

A

TTI STEEL STRUT (QTY 16)
 OUTSIDE DIMS: 2.44" X 1.63"
 WALL THICKNESS: .106"

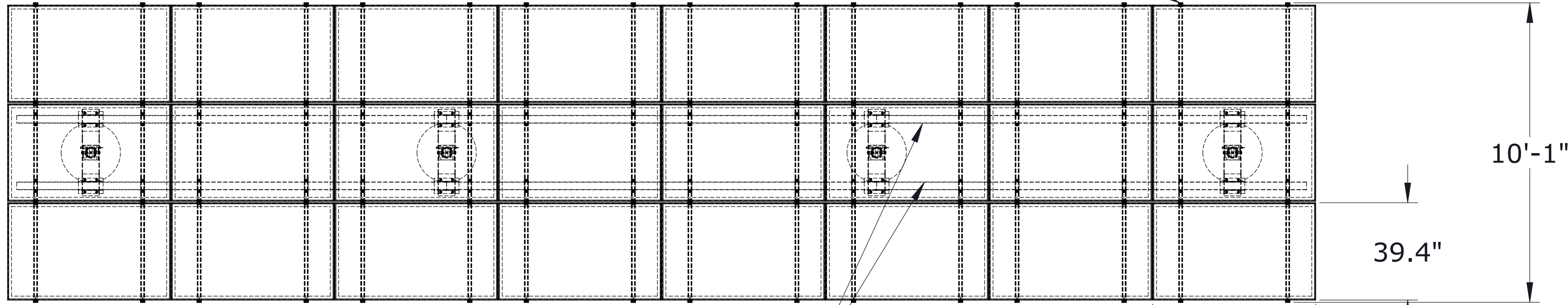

TTI STEEL TUBE (QTY 6)
 OUTSIDE DIMS: 3.94" X 3.15"
 WALL THICKNESS: .118"

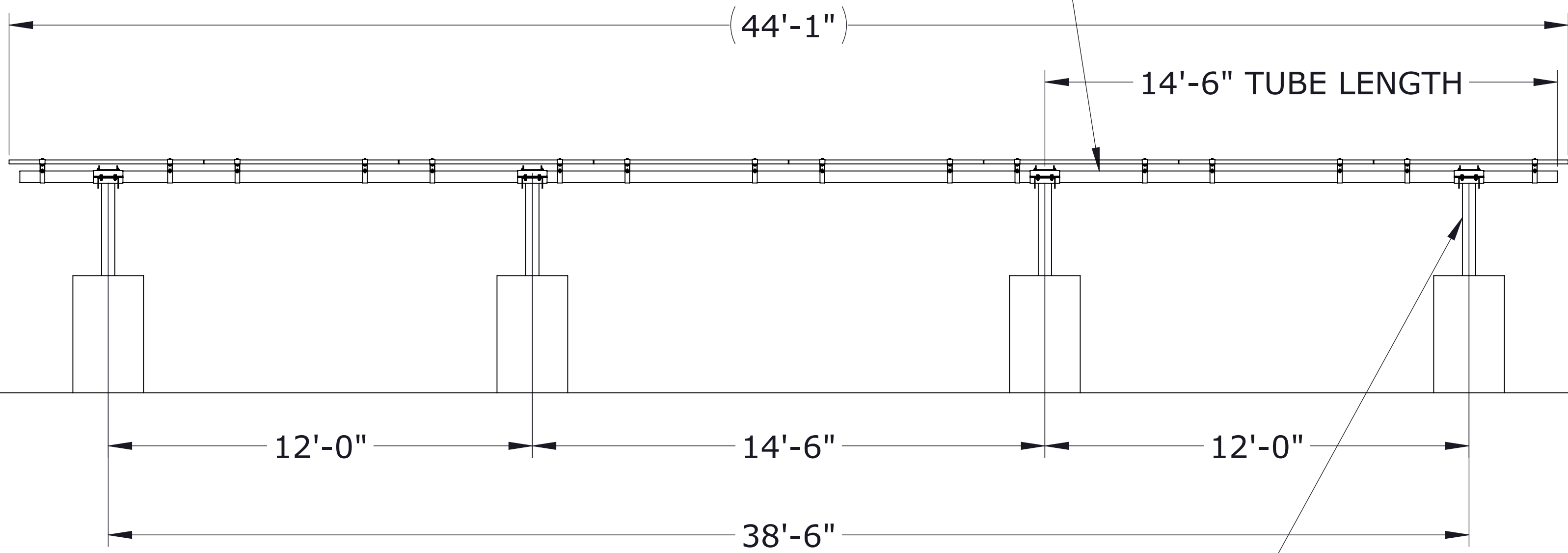

COLUMN BY OTHERS (QTY 4) - TYPICALLY 4" STD PIPE
 11" MIN LENGTH OF 4" STD PIPE (OR SIMILAR) REQUIRED FOR CONNECTION
 MAY BE ADAPTED TO LARGER PIPE BELOW CONNECTION

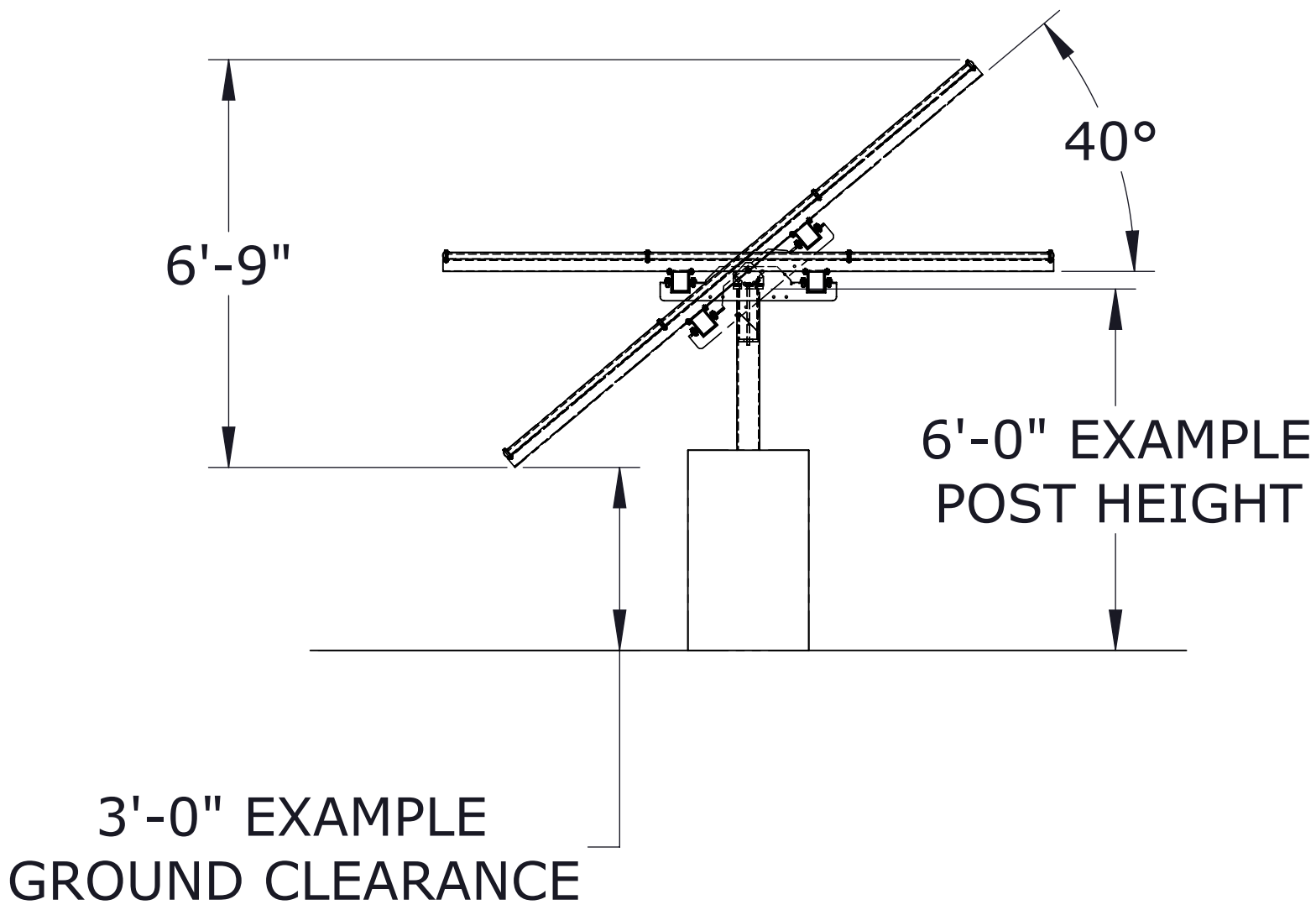

PROPERTY OF THOMPSON TECHNOLOGY INDUSTRIES, INC. CONFIDENTIAL. THIS DRAWING AND ANY DATA, DESCRIPTION, AND OTHER INFORMATION CONTAINED HEREIN ARE CONSIDERED AS PROPRIETARY AND THE EXCLUSIVE PROPERTY OF THOMPSON TECHNOLOGY INDUSTRIES, INC. AND SHALL NOT BE PUBLISHED, REPRODUCED, COPIED, DISCLOSED, OR USED, IN WHOLE OR IN PART, FOR ANY PURPOSE WITHOUT THE EXPRESS WRITTEN PERMISSION OF A DULY AUTHORIZED REPRESENTATIVE OF THOMPSON TECHNOLOGY INDUSTRIES, INC. ALL RIGHTS RESERVED.

DIMENSIONS IN FT-IN
 DIMENSIONS ARE FOR
 REFERENCE ONLY

THIRD ANGLE PROJECTION

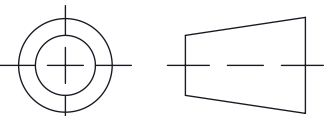

DESCRIPTION
SRP-5kw-ATGM-SW230-TTI

WEIGHT: 762 lb
 DRAWING NUMBER: **T-1004-644**

SCALE: 1:32
 SHEET: 1 OF 1

REV
A

8

7

6

5

4

3

2

1

8

7

6

5

4

3

2

1