

## **SolarDock® Pre-Installation Information Tip Sheet**

### **Roof Loading:**

When loading the roof please note that the SolarDock system will be constructed from the northernmost part of the roof to the Southern most part of the roof. Ideally you should not stage materials in the designed “Footprint” for the SolarDock array. To do so generally impedes the progress of the installation by requiring redundant handling of material on the roof. Generally roof loading along the perimeter of the building area will work best with the roof tolerance as well as ease of installation.

### **Field Inspection:**

The installer and designer should inspect the roof prior to finalizing the array designs. Typical field issues revolve around roof drains, drainage deflection, roof ridges, aeration pipes, and other rooftop equipment (shading). We can assist you with design changes, and on site field changes, but most of these can be avoided through a final field inspection.

### **Tools:**

The installer should have 1 Drill/Screw Gun per 2 installers. If battery powered, back up batteries should be on site.

Each drill should have 3/16” drill bits for pre-drilling holes in the SolarDock for sheet metal screws, 5/16” drill bits for drilling holes through the SolarDock at “T”-bar and Clip Angle attachments for stainless steel Bolt/nut/washer installations.

A 3/8” nut driver should be available for installing sheet metal screws.

Installer should also have 7/16” wrench/socket wrench for tightening the nuts and bolts.

### **Hardware:**

We ship approximately 15% more hardware (Nuts/bolts/starwashers/ sheet metal screws) as well as extra clip angles. Please keep hardware in a central location, and have all installers empty aprons nightly in the central location. We will gladly supply additional hardware if you are coming up short, but often this is due to misplaced hardware on the site.

Tape measures, chalk, chalk lines, and spray paint can be help on the site.

### **General:**

Please read the installation manual beforehand. If you have any questions, please contact us and we will assist you in any way possible.

**SolarDock**<sup>®</sup>  
Innovative Solar Solutions



## **Installation Manual**

SolarDock<sup>®</sup> Solar Electric  
Non-roof Penetrating  
Module Mounting System



11/11/08

## **TABLE OF CONTENTS**

- 1.0 Introduction
- 2.0 Product Description
- 3.0 Installation Process
- 4.0 FAQ'S
- 5.0 Drawings
- 6.0 SolarDock Parts List



## **1.0 - INTRODUCTION**

Thank you for choosing the SolarDock® photovoltaic module mounting system. We are confident that you'll find this revolutionary mounting system easy to understand and install.

This patented mounting system is a simple, cost effective solution for mounting solar modules, on both flat roofs and on the ground. This manual outlines the installation process step by step for installing a SolarDock system.

SolarDocks are manufactured to order. As the customer, you simply provide us with:

- The type of solar modules being used (brand and model number).
- The size of the array.
- The roof plan.

A SolarDock designer will work with you to configure the proposed solar array. Once your design is completed, the SolarDock units will be custom manufactured to these specifications and shipped to your location.

All of the installation steps outlined in this manual must be followed in order to qualify for UL certification.



## **2.0 - PRODUCT DESCRIPTION**

The SolarDock solar electric mounting system allows solar modules to be mounted either on the ground or on a building's flat roof.

- SolarDocks are manufactured from aluminum sheets, which are bent to form two sides of a right triangle. The hypotenuse (or longest side) of the triangle is created by attaching the solar module to the aluminum base.
- Each SolarDock is 10'-0" in length. These 10'-0" sections are set end to end to create the desired row length for the solar array being assembled.
- The SolarDock is a ballasted system, meaning it is held in place by having weight placed on it. Typically, concrete block is used for this purpose. The blocks are set inside on the base of the SolarDock at a pre-determined spacing based on local wind load criteria. As a result, there is no need to anchor the SolarDock mechanically to the building, avoiding the need for any roof penetrations.
- The rows of the array are tied together using aluminum "T" angles which run perpendicular to the rows every 10'-0" on center. This additional reinforcement allows the SolarDocks to resist the wind loads.
- SolarDock modules have ventilated end caps, as well as stamped ventilation louvers on the front and back sides. The air flow allowed by this design helps to keep the solar modules as cool as possible.
- SolarDocks are constructed of 0.063" mill certified sheet aluminum. The screw and bolt fasteners are stainless steel. These materials assure a long useful life in the field.
- Attached to the bottom of each 10'-0" section of SolarDock are (2) pieces of polystyrene insulation, measuring 1" thick by 4'-0" long. This insulation protects the roofing material from the underside of the SolarDock and creates channels for rainwater to flow through.

## 3.0 – INSTALLATION PROCESS

### INITIAL POSITIONING

---

**Step 1: Arrange the T-Bars in parallel columns, running from the back to the front of the array.**

In most cases, several sections of T-Bar will be joined to make a column.

For now, place these sections end-to-end so that they are ready to be connected.



**Step 2: Connect sections of T-Bar with a T-Bar Splice.**

The splice joins two sections of T-Bar end-to-end.

To make the connection, insert a 1/4" screw with a 1/4" flat washer through the outside of the T-Bar.

Thread the screw through a 1/4" lock washer and 1/4" hex nut on the other side.

Tighten the screw so that the two pieces of T-Bar are securely joined.



T-Bar Splice



Screw - Flat Washer - Locking Washer - Nut



Completed connection

**Step 3: Connect Clip Angles to T-Bars.**

The Clip Angles are used to position and connect the Docks to the T-Bars.

The T-Bar is pre-drilled with holes to connect the Clip Angles.

The Clip Angles should be placed with the flat side facing the front of the front of the array.

Connect the Clip Angles using the same screw/washer/nut combo used in step two. Leave the connection loose as it will need to be adjusted when Docks are attached.

The T-Bars on the outside of the array will only use one Clip Angle. T-Bars on the inside of the array will use two Clip Angles.

**Step 4: Position T-Bars in their approximate final location.**

Proper placement of the T-Bars at this point in the installation will prevent having to move the assembled system later in the process.

Starting with one of the outside T-Bars, determine final placement, being sure to allow the appropriate distance from parapets and obstructions.

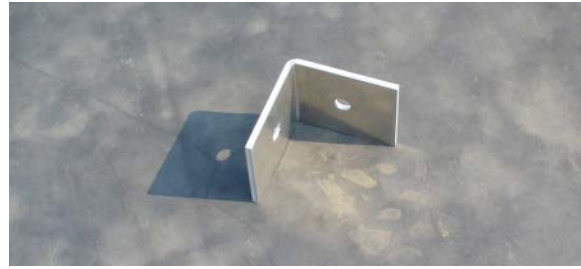

Clip Angle

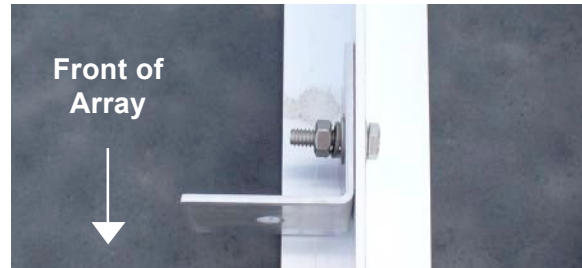

Outside T-Bar connection



Inside T-Bar connection



### **Step 4 (continued):**

From that T-Bar, place the next T-Bar 10' ¼" away. Mark this location with a crayon/pen so it can be identified later if necessary.

Measure the distance between the two T-Bars, checking that the 10' ¼" distance is maintained throughout.

Repeat this measuring process for each length of T-Bar.

Note: If the layout uses a shorter length of dock, place T-Bar at the distance noted on the installation diagram included with the SolarDocks.



## **INSTALLING SOLARDOCKS**

---

### **Step 5: Place back row of SolarDocks**

Begin the placement of the SolarDocks at the rear of the array.

Starting at the back of the array ensures the positioning of the system completed in Step 4, and allows for a more efficient installation.

The back of the dock should be placed up against the flat part of the clip angle attached in Step 3.

On the outside T-Bar connections, leave the connection a bit loose to allow room for placement of the End Caps later on in the process.



### **Step 6: Connecting the SolarDocks to the T-Bars**

Using the Clip Angle hole as a guide, drill a hole through the SolarDock.

Connect the SolarDock to the Clip Angle using the same screw/washer/nut combinations described in Step 2.



### **Step 7: Attach Dock Splice Plate to Docks**

After all the SolarDocks in the row are attached to the T-Bars, attach the Dock Splice Plates above the T-Bar connections.

The plate should be centered horizontally between the docks and vertically between the T-Bar and the upper lip of the docks.



### **Step 8: Completing placement of SolarDocks**

Moving forward on the array, repeat Steps 5 & 7 for each additional row.

As in Step 5, SolarDocks should be placed with the back up against the Clip Angles.



### **Step 9: Place ballast in SolarDocks**

Distribute ballast inside the SolarDocks based on the ballast plan/requirement provided by SolarDock.

*Note: You should consult local building codes and code authorities to ensure that the weight of the ballasted system will not exceed local building load limits.*

SolarDock has found that 4" x 8" x 16" concrete block works well and is economical.



## INSTALLING MODULES

---

*You should consult and follow the Module Manufacturer's installation instructions to assure proper grounding of the modules when securing them to the SolarDock.*

*The SolarDock is not designed to be a grounding path from the modules. Individual grounding jumpers and wires should be run between panels to create a grounding path.*

### **Step 10: Placing 1<sup>st</sup> module in a row**

Starting at the end of a row, set one of the Inside Straps (the 3" wide straps) where the middle of the 1<sup>st</sup> module will fall. Modules are oriented in landscape format, with the long edge being at the bottom.

This strap offers additional strength to the module frame once in position. The strap sits flat in the upper and lower channels, with the end legs facing up.

Now place the lower edge of the first module into the bottom channel of the SolarDock, holding the module upright and flush with the end.

Now lay the top of the module into the upper channel of the SolarDock.

The first module is now in position.

The Dock, Inside Strap, and Module are attached by drilling through each and securing with 3/4" x 5/16" stainless steel screws.

*The installer should consult the module manufacturer to confirm that the attachment procedure meets the module manufacturer's requirements.*



### **Step 11: Placing 2nd module in a row**

Place another Inside Strap where the middle of the 2nd module will fall.

Set the bottom edge of the second module on the lower channel of the SolarDock, leaving approximately 1/2" between the 1<sup>st</sup> and 2<sup>nd</sup> modules to allow for thermal expansion of the modules.

Make the module cable connections from the first module to the next, and set the 2<sup>nd</sup> module down in the SolarDock.

Place an Outside Strap (the 2" wide straps) over the gap between the two modules to hold the modules in place while the remaining modules in the row are set in the docks. These straps will be secured to the SolarDocks later in the process.

*Note: Outside straps are not used at the ends of the row. The panel is secured in Step 14 using security screws.*

### **Step 12: Placing remaining modules in the row**

Repeat Steps 10 & 11 for the remaining modules in the row.

### **Step 13: Attach Outside Straps to SolarDocks**

Use two (2) 3/4" x 5/16" stainless steel screws to attach each of the Outside Straps to the upper and lower lips of the SolarDock.

The included stainless steel security fasteners are used to screw the SolarDock, the middle strap and the module together, top and bottom. The security screws require a special bit, making unauthorized removal more difficult.

### **Step 14: Secure modules at end of rows to SolarDocks**

The two modules at either end of the rows have additional security screws installed at the ends, since there are no straps in these locations.

### **Step 15: Attach End Caps to Each Row**

Attach the ventilated End Caps to the end of each row with the enclosed fasteners.

### **Step 16: Repeat Steps 9-15 for each remaining row**

#### **Notes on electrical installation:**

- 1) You should consult and follow the Module Manufacturer's installation instructions to assure proper grounding of the modules when securing them to the SolarDock
- 2) The SolarDock is not designed to be a grounding path from the modules. Individual grounding jumpers and wires should be run between panels to create a grounding path
- 3) The wiring from each string is taken to a DC disconnect box or to a string paralleling junction box by means of rigid conduit, where it is taken to an inverter (s). A ground wire needs to be anchored to the SolarDock and run to building ground for each row.
- 4) All electrical work needs to conform to NEC Articles 250 & 690.
- 5) The number of modules per string and the inverter(s) selection/sizing should be handled by an electrical engineer experienced in photovoltaic design.

## **4.0 – FREQUENTLY ASKED QUESTIONS**

- 1) What materials does the installer need to supply?
  - The ballast material and anything associated with electrical.
  
- 2) How long does it take to install a system using the SolarDock?
  - A four person crew should be able to install 15 – 25 kW DC in one day. This does not include electrical.
  
- 3) How much ballast is required for the SolarDock system?
  - The ballast requirements are dependent on the design wind load, the solar module being used & the angle of the SolarDock. McConnell Energy Solutions can assist your structural engineer in determining the ballast required.
  
- 4) What maintenance is required with the SolarDock?
  - It is important to check the roof periodically to make sure that debris does not accumulate against the system.
  - It would be beneficial to wash the surface of the modules once a quarter to maintain peak performance.
  
- 5) How long will a SolarDock system last?
  - The SolarDock is made from high quality aluminum. The fasteners are all stainless steel. Therefore, the service life should be in excess of thirty years.

## **5.0 – DRAWINGS**

- 5.1 Front Elevation
- 5.2 Rear Elevation
- 5.3 End Elevation
- 5.4 Array Plan
- 5.5 Optional InverterDock Mounting Board



## 5.1 — FRONT ELEVATION

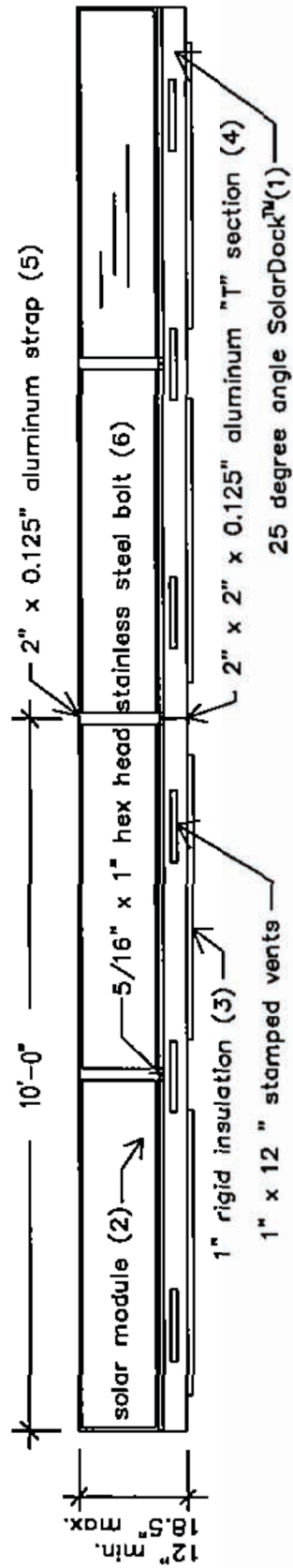

## 5.2 – REAR ELEVATION

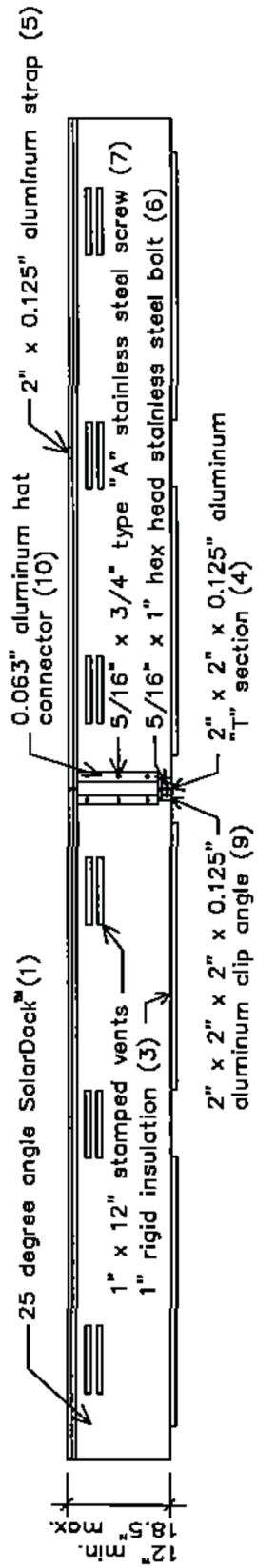

### 5.3 – END ELEVATION & SECTION

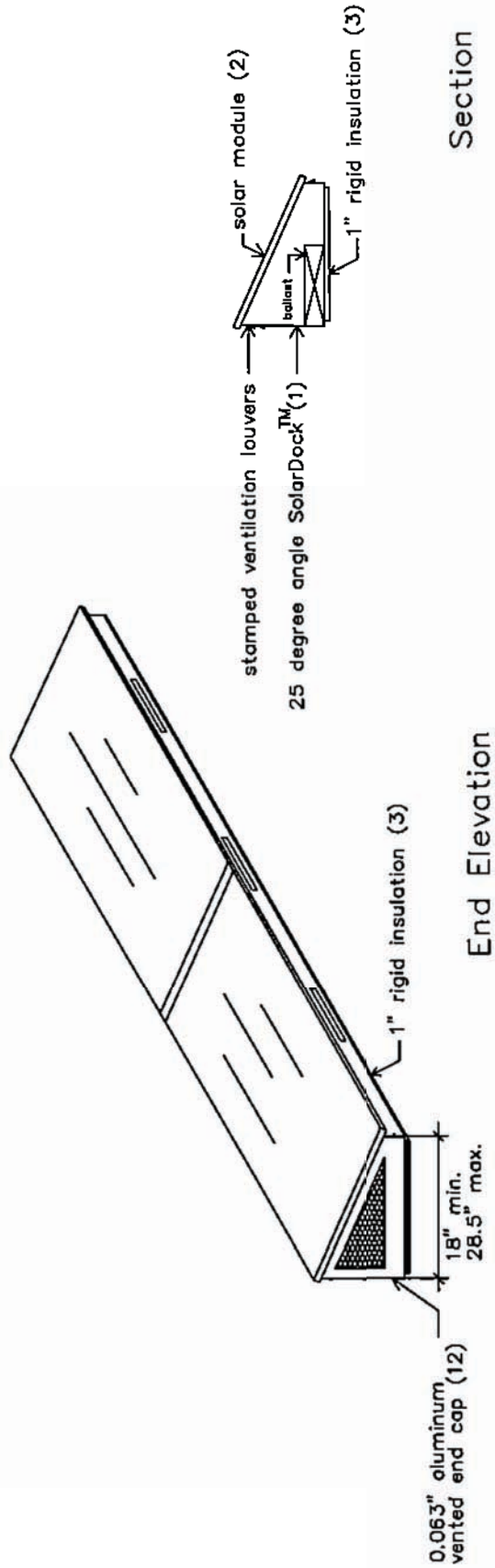

5.4 – ARRAY PLAN

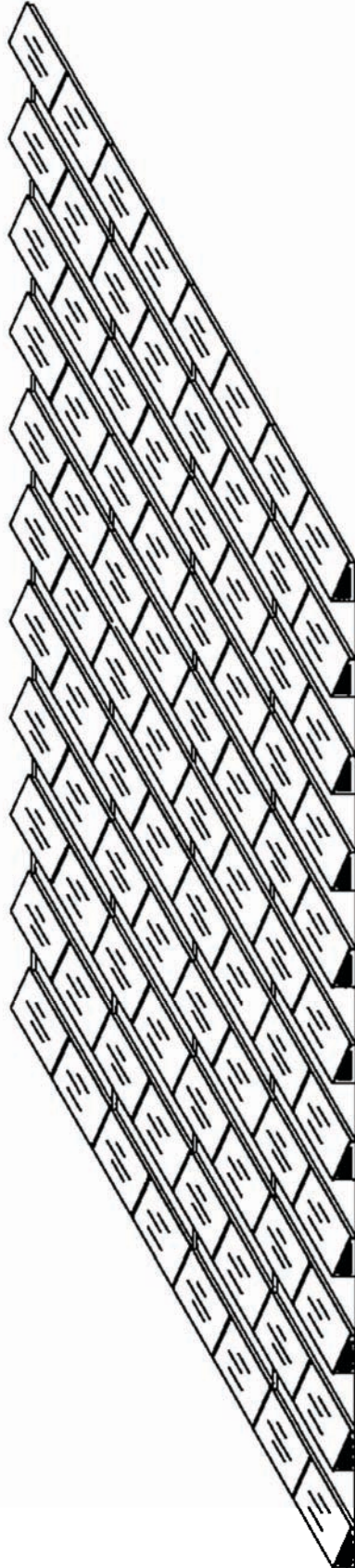

## 5.5 – OPTIONAL INVERTER MOUNTING BOARD (15) REAR ELEVATION

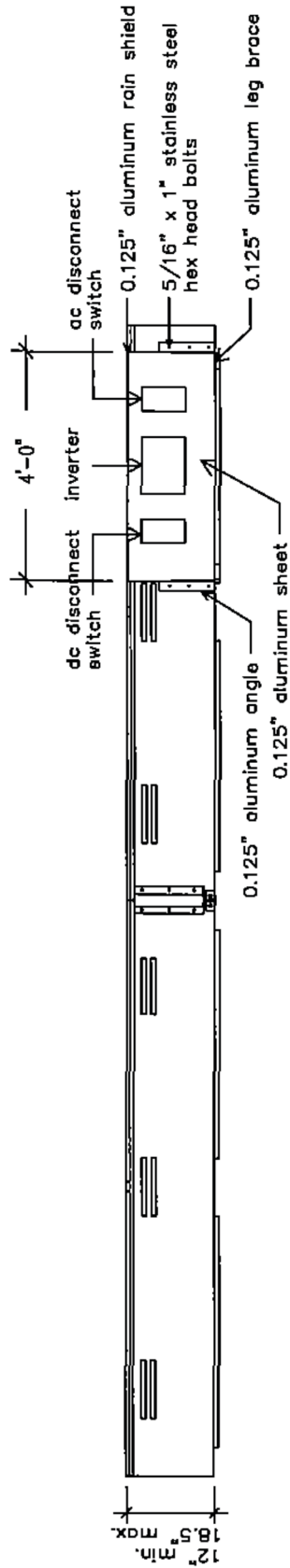

## **6.0 – SolarDock® PARTS LIST**

<u>Part Number</u>	<u>Part Name</u>
(1)	SolarDock® (25 degree angle)
(2)	Solar module
(3)	Polystyrene insulation board adhered to the bottom of the SolarDock
(4)	2" x 2" x 0.125" x 14'-0" aluminum "T" brace
(5)	2" x 0.125" aluminum splice strap
(6)	5/16" x 1" hex head stainless steel bolt
(7)	5/16" x 3/4" type "A" stainless steel sheet metal screw
(8)	3" x 0.063" aluminum module strap
(9)	2" x 2" x 2" x 0.125" aluminum clip angles
(10)	Aluminum hat connector
(11)	Stainless steel security screw fasteners
(12)	Vented aluminum end cap
(13)	Double sided Firestone Quick Seam splice tape
(14)	Custom degree angle SolarDock
(15)	Optional InverterDock mounting board





**1201 North Market Street  
Suite 400  
Wilmington, DE 19801**

**Phone: (302) 504-0124  
Fax: (302) 428-0723**